



UNIVERSITY OF CAMBRIDGE INTERNATIONAL EXAMINATIONS  
International General Certificate of Secondary Education

www.PapaCambridge.com

**CHEMISTRY**

**0620/12**

Paper 1 Multiple Choice

**October/November 2010**

**45 Minutes**

Additional Materials: Multiple Choice Answer Sheet  
Soft clean eraser  
Soft pencil (type B or HB is recommended)

\* 7 2 1 0 4 3 7 4 5 0 \*

**READ THESE INSTRUCTIONS FIRST**

Write in soft pencil.

Do not use staples, paper clips, highlighters, glue or correction fluid.

Write your name, Centre number and candidate number on the Answer Sheet in the spaces provided unless this has been done for you.

There are **forty** questions on this paper. Answer **all** questions. For each question there are four possible answers **A, B, C** and **D**.

Choose the **one** you consider correct and record your choice in **soft pencil** on the separate Answer Sheet.

**Read the instructions on the Answer Sheet very carefully.**

Each correct answer will score one mark. A mark will not be deducted for a wrong answer.

Any rough working should be done in this booklet.

A copy of the Periodic Table is printed on page 16.

You may use a calculator.

This document consists of **16** printed pages.



- 1 In which changes do the particles move further apart?

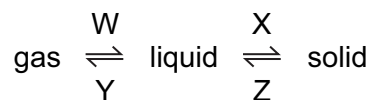

- A** W and X      **B** W and Z      **C** X and Y      **D** Y and Z
- 2 A mixture of ethanol and methanol are separated by fractional distillation.  
This method of separation depends on a difference in property X of these two alcohols.  
What is property X?

- A** boiling point  
**B** colour  
**C** melting point  
**D** solubility
- 3 Chromatography is used to find out if a banned dye, P, is present in foodstuffs.

The results are shown in the diagram.

Which foodstuff contains P?

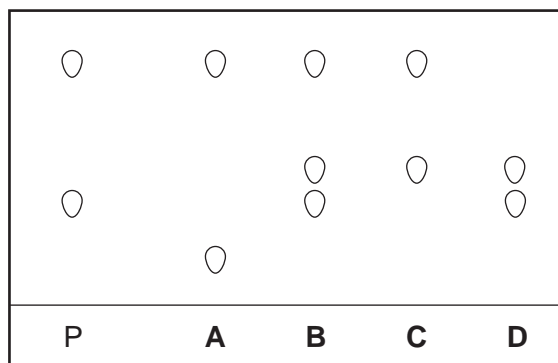

- 4 Which diagram does **not** show the outer shell electrons in the molecule correctly?

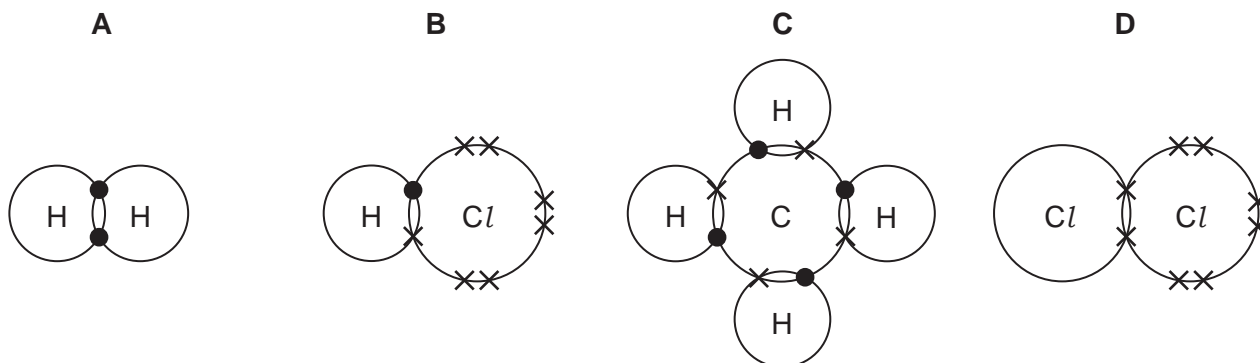

- 5 The chemical compositions of two substances, W and X, are given.

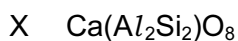
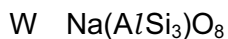

Which statements are correct?

- 1 W and X contain the same amount of oxygen.
- 2 W contains three times as much silicon as X.
- 3 X contains twice as much aluminium as W.

- A** 1 and 2      **B** 1 and 3      **C** 2 and 3      **D** 1, 2 and 3

- 6 The electronic structures of atoms X and Y are shown.

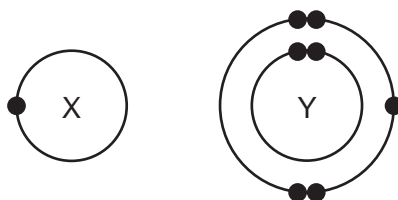

X and Y form a covalent compound.

What is its formula?

- A**  $\text{XY}_5$       **B**  $\text{XY}_3$       **C**  $\text{XY}$       **D**  $\text{X}_3\text{Y}$

- 7 Element X is shiny and can be formed into a sheet by hammering.

Which row correctly describes the properties of element X?

	conducts electricity	melts below $25^\circ\text{C}$
<b>A</b>	✓	✓
<b>B</b>	✓	x
<b>C</b>	x	✓
<b>D</b>	x	x

- 8 Two isotopes of hydrogen are  ${}^1_1\text{H}$  and  ${}^2_1\text{H}$ .

Which diagram shows the arrangement of particles in the two isotopes?

	${}^1_1\text{H}$	${}^2_1\text{H}$	
<b>A</b>			key
<b>B</b>			⊖ = an electron
<b>C</b>			⊕ = a proton
<b>D</b>			⊘ = a neutron
			⊖ = a nucleus

- 9 The table shows the structure of different atoms and ions.

particle	proton number	nucleon number	number of protons	number of neutrons	number of electrons
Mg	12	24	12	W	12
$\text{Mg}^{2+}$	X	24	12	12	10
F	9	19	9	Y	9
$\text{F}^-$	9	19	9	10	Z

What are the values of W, X, Y and Z?

	W	X	Y	Z
<b>A</b>	10	10	9	9
<b>B</b>	10	12	10	9
<b>C</b>	12	10	9	10
<b>D</b>	12	12	10	10

10 Element X has a nucleon (mass) number of 19 and a proton (atomic) number of 9.

To which group in the Periodic Table does it belong?

- A I                      B III                      C VII                      D 0

11 Substance X was electrolysed in an electrolytic cell.

A coloured gas was formed at the anode and a metal was formed at the cathode.

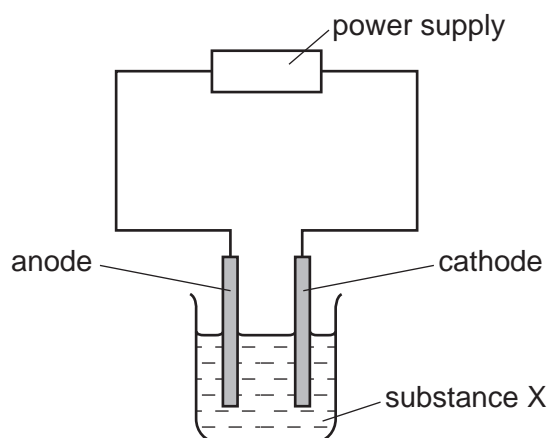

What is substance X?

- A aqueous sodium chloride  
B molten lead bromide  
C molten zinc oxide  
D solid sodium chloride

- 12 The diagram shows apparatus used in an attempt to electroplate a metal ring with copper.

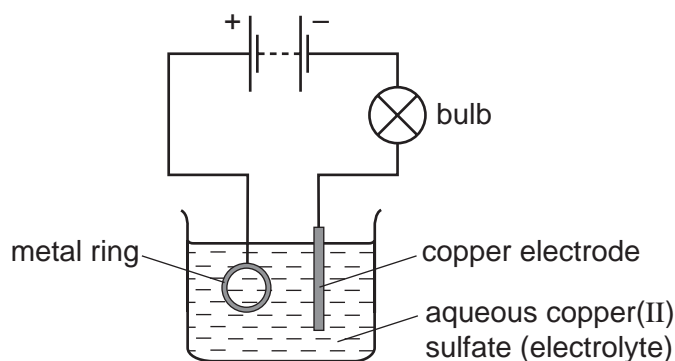

The experiment did not work.

What change is needed in the experiment to make it work?

- A Add solid copper(II) sulfate to the electrolyte.
  - B Increase the temperature of the electrolyte.
  - C Replace the copper electrode by a carbon electrode.
  - D Reverse the connections to the battery.
- 13 When concentrated sodium chloride solution is electrolysed, elements X and Y are formed.

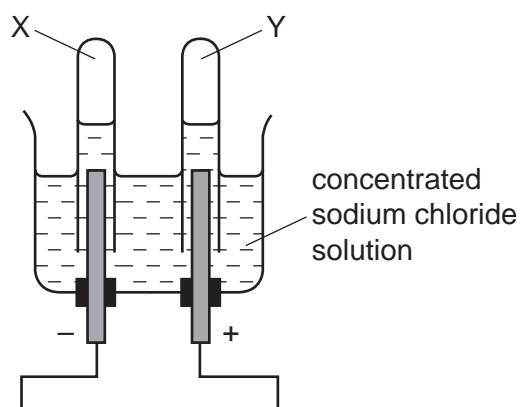

What are X and Y?

	X	Y
A	chlorine	hydrogen
B	hydrogen	chlorine
C	hydrogen	oxygen
D	oxygen	hydrogen

- 14 Calcium carbonate was reacted with hydrochloric acid in a conical flask. The flask was placed on a balance and the mass of the flask and contents was recorded as the reaction proceeded.

During the reaction, carbon dioxide gas was given off.

The reaction was carried out at two different temperatures.

Which row is correct?

	change in mass	temperature at which mass changed more quickly
<b>A</b>	decrease	higher temperature
<b>B</b>	decrease	lower temperature
<b>C</b>	increase	higher temperature
<b>D</b>	increase	lower temperature

- 15 Some barium iodide is dissolved in water.

Aqueous lead(II) nitrate is added to the solution until no more precipitate forms.

This precipitate, X, is filtered off.

Dilute sulfuric acid is added to the filtrate and another precipitate, Y, forms.

What are the colours of precipitates X and Y?

	X	Y
<b>A</b>	white	white
<b>B</b>	white	yellow
<b>C</b>	yellow	white
<b>D</b>	yellow	yellow





- 20 The red colour in some pottery glazes may be formed as a result of the reactions shown.

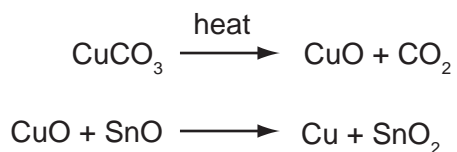

These equations show that .....1..... is oxidised and .....2..... is reduced.

Which substances correctly complete gaps 1 and 2 in the above sentence?

	1	2
<b>A</b>	CO <sub>2</sub>	SnO <sub>2</sub>
<b>B</b>	CuCO <sub>3</sub>	CuO
<b>C</b>	CuO	SnO
<b>D</b>	SnO	CuO

- 21 The table shows some reactions of the halogens.

Which reaction is the most likely to be explosive?

reaction	chlorine gas	bromine gas	iodine gas
reaction with hydrogen	<b>A</b>	<b>B</b>	<b>C</b>
reaction with iron	very vigorous	less vigorous	<b>D</b>

- 22 Which compound is likely to be coloured?

**A** KMnO<sub>4</sub>      **B** KNO<sub>3</sub>      **C** K<sub>2</sub>CO<sub>3</sub>      **D** K<sub>2</sub>SO<sub>4</sub>

- 23 A salt is made by adding an excess of an insoluble metal oxide to an acid.

How can the excess metal oxide be removed?

- A** chromatography  
**B** crystallisation  
**C** distillation  
**D** filtration

- 24 The oxide of element X was added to an acid. It reacted to form a salt and water.

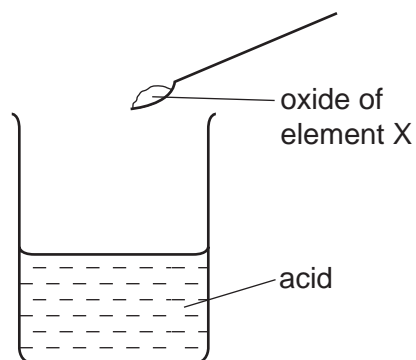

What is the pH of the acid before the reaction and what type of element is X?

	pH	type of element X
<b>A</b>	greater than 7	metal
<b>B</b>	greater than 7	non-metal
<b>C</b>	less than 7	metal
<b>D</b>	less than 7	non-metal

- 25 The table compares the properties of Group I elements with those of transition elements.

Which entry in the table is correct?

	property	Group I elements	transition elements
<b>A</b>	catalytic activity	low	high
<b>B</b>	density	high	low
<b>C</b>	electrical conductivity	low	high
<b>D</b>	melting point	high	low



28 Which diagram could represent the structure of an alloy?

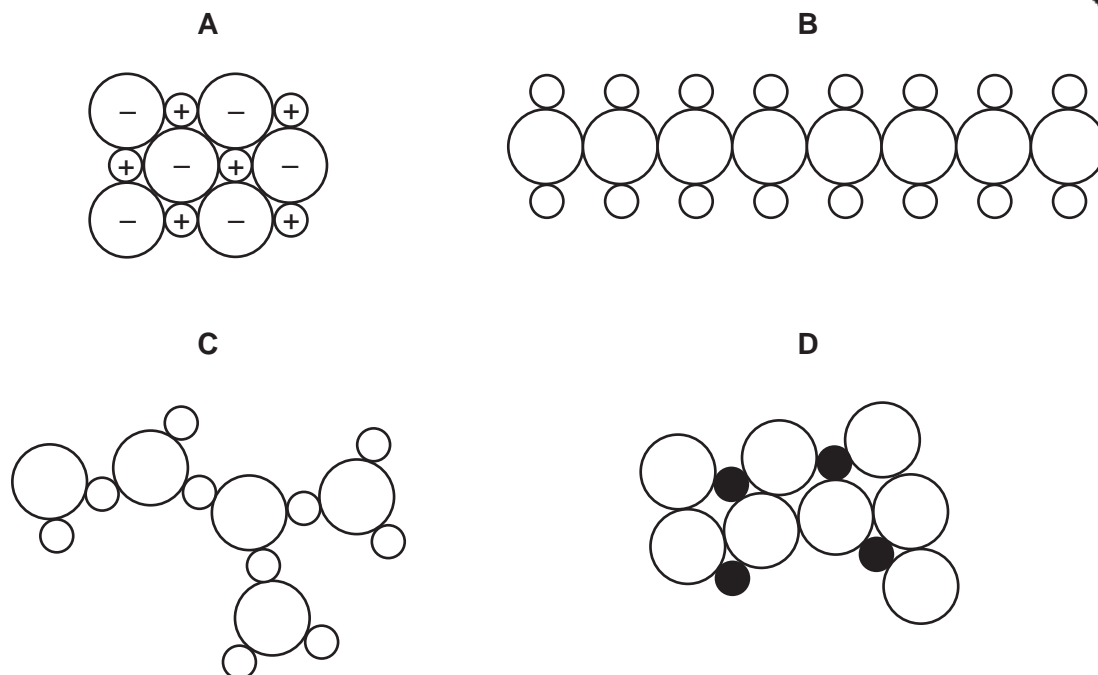

29 The diagram shows the materials used in the production of steel from impure iron.

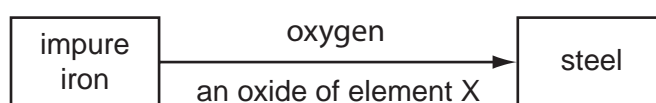

What could element X be?

- A** calcium
  - B** carbon
  - C** nitrogen
  - D** sulfur
- 30 Which property do **all** metals have?
- A** Their boiling points are low.
  - B** Their densities are low.
  - C** They conduct electricity.
  - D** They react with water.

31 Which pollutant, found in car exhaust fumes, does **not** come from the fuel?

- A carbon monoxide
- B hydrocarbons
- C lead compounds
- D nitrogen oxides

32 Which diagram shows a common use of stainless steel?

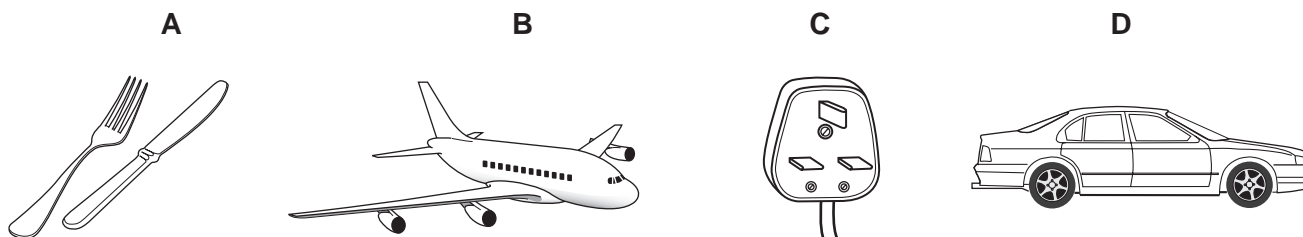

33 Why is chlorination used in water treatment?

- A to kill bacteria in the water
- B to make the water neutral
- C to make the water taste better
- D to remove any salt in the water

34 A test-tube containing damp iron wool is inverted in water.

After three days, the water level inside the test-tube has risen.

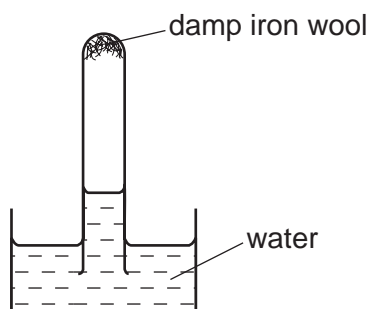

Which statement explains this rise?

- A Iron oxide has been formed.
- B Iron wool has been reduced.
- C Oxygen has been formed.
- D The temperature of the water has risen.

35 Which information about carbon dioxide and methane is correct?

		carbon dioxide	methane
<b>A</b>	formed when vegetation decomposes	✓	x
<b>B</b>	greenhouse gas	✓	✓
<b>C</b>	present in unpolluted air	x	x
<b>D</b>	produced during respiration	x	✓

36 A bag of fertiliser 'Watch it grow' contains ammonium sulfate and potassium sulfate.

Which of the three elements N, P and K does 'Watch it grow' contain?

	N	P	K
<b>A</b>	✓	✓	x
<b>B</b>	✓	x	✓
<b>C</b>	x	✓	x
<b>D</b>	x	x	✓

37 In an oil refinery, crude oil is separated into useful fractions.

The diagram shows some of these fractions.

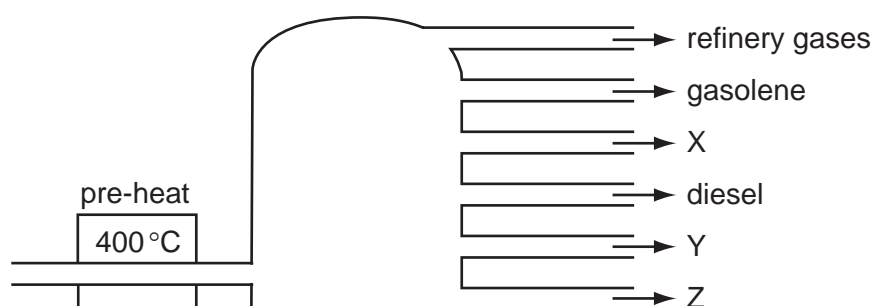

What are fractions X, Y and Z?

	X	Y	Z
<b>A</b>	fuel oil	bitumen	paraffin (kerosene)
<b>B</b>	fuel oil	paraffin (kerosene)	bitumen
<b>C</b>	paraffin (kerosene)	bitumen	fuel oil
<b>D</b>	paraffin (kerosene)	fuel oil	bitumen



**DATA SHEET**  
**The Periodic Table of the Elements**

		Group																																																																																												
I	II	III	IV	V	VI	VII	0																																																																																							
7 <b>Li</b> Lithium 3	9 <b>Be</b> Beryllium 4	1 <b>H</b> Hydrogen 1	11 <b>B</b> Boron 5	12 <b>C</b> Carbon 6	14 <b>N</b> Nitrogen 7	16 <b>O</b> Oxygen 8	19 <b>F</b> Fluorine 9	20 <b>Ne</b> Neon 10	23 <b>Na</b> Sodium 11	24 <b>Mg</b> Magnesium 12	27 <b>Al</b> Aluminium 13	28 <b>Si</b> Silicon 14	31 <b>P</b> Phosphorus 15	32 <b>S</b> Sulfur 16	35.5 <b>Cl</b> Chlorine 17	40 <b>Ar</b> Argon 18	39 <b>K</b> Potassium 19	40 <b>Ca</b> Calcium 20	45 <b>Sc</b> Scandium 21	48 <b>Ti</b> Titanium 22	51 <b>V</b> Vanadium 23	52 <b>Cr</b> Chromium 24	55 <b>Mn</b> Manganese 25	56 <b>Fe</b> Iron 26	59 <b>Co</b> Cobalt 27	59 <b>Ni</b> Nickel 28	64 <b>Cu</b> Copper 29	65 <b>Zn</b> Zinc 30	70 <b>Ga</b> Gallium 31	73 <b>Ge</b> Germanium 32	75 <b>As</b> Arsenic 33	79 <b>Se</b> Selenium 34	80 <b>Br</b> Bromine 35	84 <b>Kr</b> Krypton 36	85 <b>Rb</b> Rubidium 37	88 <b>Sr</b> Strontium 38	89 <b>Y</b> Yttrium 39	91 <b>Zr</b> Zirconium 40	93 <b>Nb</b> Niobium 41	96 <b>Mo</b> Molybdenum 42	101 <b>Ru</b> Ruthenium 44	106 <b>Pd</b> Palladium 46	108 <b>Ag</b> Silver 47	112 <b>Cd</b> Cadmium 48	115 <b>In</b> Indium 49	119 <b>Sn</b> Tin 50	122 <b>Sb</b> Antimony 51	128 <b>Te</b> Tellurium 52	131 <b>Xe</b> Xenon 54	133 <b>Cs</b> Caesium 55	137 <b>Ba</b> Barium 56	139 <b>La</b> Lanthanum 57	178 <b>Hf</b> Hafnium 72	181 <b>Ta</b> Tantalum 73	184 <b>W</b> Tungsten 74	186 <b>Re</b> Rhenium 75	190 <b>Os</b> Osmium 76	192 <b>Ir</b> Iridium 77	195 <b>Pt</b> Platinum 78	197 <b>Au</b> Gold 79	201 <b>Hg</b> Mercury 80	204 <b>Tl</b> Thallium 81	207 <b>Pb</b> Lead 82	209 <b>Bi</b> Bismuth 83	210 <b>Po</b> Polonium 84	210 <b>At</b> Astatine 85	226 <b>Ra</b> Radium 88	227 <b>Ac</b> Actinium 89	232 <b>Th</b> Thorium 90	238 <b>U</b> Uranium 92	238 <b>Np</b> Neptunium 93	238 <b>Pu</b> Plutonium 94	238 <b>Am</b> Americium 95	238 <b>Cm</b> Curium 96	238 <b>Bk</b> Berkelium 97	238 <b>Cf</b> Californium 98	238 <b>Es</b> Einsteinium 99	238 <b>Fm</b> Fermium 100	238 <b>Md</b> Mendelevium 101	238 <b>No</b> Nobelium 102	238 <b>Lr</b> Lawrencium 103	140 <b>Ce</b> Cerium 58	141 <b>Pr</b> Praseodymium 59	144 <b>Nd</b> Neodymium 60	150 <b>Sm</b> Samarium 62	152 <b>Eu</b> Europium 63	157 <b>Gd</b> Gadolinium 64	159 <b>Tb</b> Terbium 65	162 <b>Dy</b> Dysprosium 66	165 <b>Ho</b> Holmium 67	167 <b>Er</b> Erbium 68	169 <b>Tm</b> Thulium 69	173 <b>Yb</b> Ytterbium 70	175 <b>Lu</b> Lutetium 71

\*58-71 Lanthanoid series  
†90-103 Actinoid series

Key	a	X	a = relative atomic mass
	b	X	X = atomic symbol
		b	b = proton (atomic) number

The volume of one mole of any gas is 24 dm<sup>3</sup> at room temperature and pressure (r.t.p.).